



 **STAR400**

Data Center High Density Connectivity Solution

STAR400 High Density Connectivity Solution

The STAR400 high density pre-terminated MTP® 8-Fibers modules enable rapid deployment and are designed to provide quick and easy management of Moves, Adds and Changes (MACs) of High-density patch cords and MTP® horizontal cabling and backbone connections in Data Centers.

The STAR400 features 8 fibers configuration. Latest technology developments show that platforms using base-8 fiber count configurations feature maximum utilization of fibers and form the optimal platform for migration to a wide range of bit rates up to 400G.

STAR400 Frames

The STAR400 fiber-optic distribution frame is a high-performance, compact housing assembly, built in stacked trays of 6 modules each. This solution applies a simple sliding-tray system that makes the modules as quick and easy to handle as intuitive plug-in components.

Features:

- TELCORDIA GR-449-CORE and TIA 942 compliant
- Sliding numbered trays allowing easy and convenient installation
- Easy labeling with built-in documentation chart.
- Colored Patch Cord routing guides in each tray allowing easy network differentiation (LAN and Storage)
- RoHS Compliant

Benefits:

- Versatile high-density solution (either MTP®- MTP® or MTP®-LC modules)
- Individual tray pull-out/handling - High density yet easy access to each port
- Low insertion loss enabling maximum connections per channel enabling structured cabling architecture as required in TIA-942.
- Built-in cabling management
- Removable top cover providing easy access to the interior of the ODF
- Combined with Bend Insensitive cables and Uniboot Patch Cords for maximum density and reliability
- All ODF's include cable holders emplacement
- All Trunks cables are delivered with cable holders for fast and tool less installation
- The ODF's include spacious back and front rewritable labels for easy management of the site

* MTP® is a registered trademark of US Conec Ltd

Specifications:

- Width: 19"
(Brackets for 21" & 23" should be ordered separately)

STAR400 1U ODF

- Handles up to 18 different types of modules arranged in 3 separate trays.
Each tray with its own fiber management.
- Depth: 543.4 mm
408.3 mm (19" profile to the back)
- Up to 144 fibers (LC), 72 (MTP)



STAR400 1U ODF

STAR400 2U ODF

- Handles up to 36 different types of modules arranged in 6 separate trays.
Each tray with its own fiber management.
- Depth: 543.4 mm
408.3 mm (19" profile to the back)
- Up to 288 fibers (LC), 144 (MTP)



STAR400 2U ODF

STAR400 4U ODF

- Handles up to 72 different types of modules arranged in 12 separate trays.
Each tray with its own fiber management.
- Depth: 543.4 mm
408.3 mm (19" profile to the back)
- Up to 576 fibers (LC), 288 (MTP)



STAR400 4U ODF

STAR400 Modules

STAR400 Modules are designed to consistently deliver the connectivity required in the most demanding environments. The modules fit into the sliding-tray system, with easy plug-in installation and easy pull-out access for MAC servicing. STAR400 modules can accommodate either MTP® to 4 LC Duplex adapters (MTP®-LC Module) or MTP® adapters in various combinations.

Features:

- TELCORDIA GR-449-CORE, IEC 61754-7, 568-C.3, IEC 11801 and TIA 942 compliant.
- Meets the current data rates' requirement for up to 10G/40G/100G and for future 400G Ethernet
- 100% Testing of Insertion & Return Loss (IL&RL)
- RoHS compliant
- Available with SM/OM4/OM3 cable types
- All Ferrules are interferometer tested

Benefits:

- Quick insertion and extraction in a compact, high density, space-saving design
- Individual tray pull-out - easy access/operation to each port
- Low Insertion Loss performance exceeding TIA 942-A connection requirements
- Built in Shuttered LC Duplex adapters ensures user safety for invisible laser beams

Specifications:

MTP®-LC Module

- Available with one rear MTP® adapter to 8 numbered front LC connections

MTP®-MTP® Module

- 10 to 40G, Up to 4 built-in MTP®-MTP® adapters providing MTP® connection points between trunks and harnesses
- 100G and 400G migration utilizing the same backbone trunk cables for the upgrade
- Up to 400G migration using MTP-16® or MTP-32® (FOCIS 18) adapters

MTP® 400G Conversion Module

- Available configurations:
- 2x3 - Two 12-fiber MTP® adapters at the rear and one 16-fiber MTP® adapters at the front.

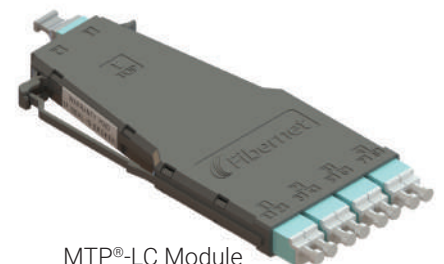

MTP®-LC Module

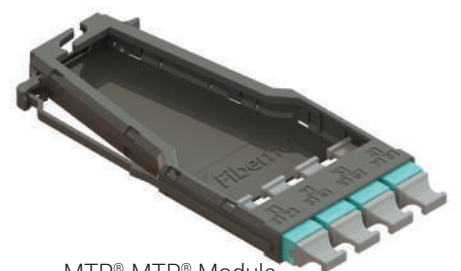

MTP®-MTP® Module

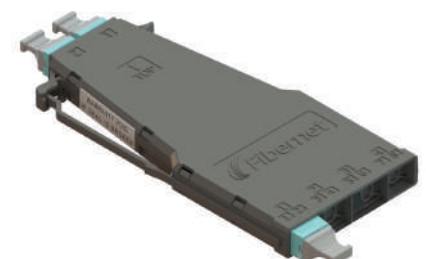

MTP® 400G Conversion Module

Fusion Splice Module

- Enables easy termination of splice cables with high-density LC connectors in Data Centers
- Holds up to 8 LC Splice connections - with 8 colour coded pigtailed and 4 LC duplex adapters
- Removable top for easy access and designated fiber management system ensuring fiber slack and bend radius

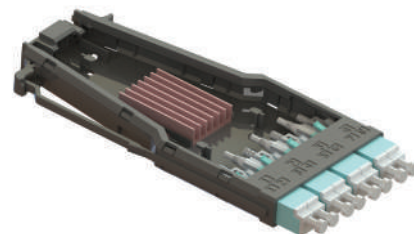

Fusion Splice Module

TAP Module

- MTP® to 8 LC, or MTP® to MTP® with front TAP connection, or MTP® to MTP® with rear TAP connection
- Contains fiber optic splitters which divide each optical signal into two outputs - live link traffic and monitoring without interruption to the live network traffic
- Different splice ratios and different performance splitters available

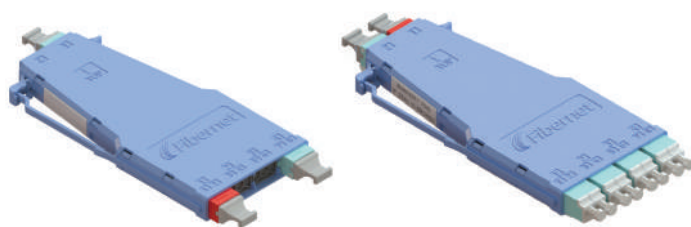

TAP Module



MTP® Cables

These cutting-edge MTP® cables are bend-insensitive and pre-terminated with MTP® Elite connectors, which offer 6 times the density of LC Duplex connectors. The cables include strain tool-less relief clips for quick cable mounting onto STAR products.

Features:

- Lab • Pulling sleeves for safe pulling installations
- LSZH-FR/HFFR jacket
- Bend insensitive fibers MM OM3, OM4 or SM (G.657A2)
- Exceeds TIA/EIA 604-5 Type MPO requirements and compliant with IEC 61754-7, Telcordia GR-1435-CORE, RoHS
- Custom configuration is available

Specifications:

MTP®Trunk Cable

- 8-144 fibers in a single, high capacity MTP® cable

MTP®-LC Fan-Out Cable

- 1 MTP® connector to 4 reversible LC Uniboot connectors

MTP® 40G Conversion Harness (8F-12F)

- 2x8F MTP® connector to 1x16F MTP® connectors
- 4x8F MTP® connector to 1x32F MTP® connectors
- Up to 400G migration using MTP-16® or MTP-32® (FOCIS 18) adapters

Benefits:

- Enable easy and cost effective migration from 10G to 40G, 100G and 400G using the same back-bone cables
- Provide excellent performance while saving space in cable ducts
- Field-proven - Installed successfully at high- density, high-availability facilities, including Disaster Recovery Plan (DRP), Business Continuity Planning (BCP) and central Data-Center sites
- Low Insertion Loss performance exceeding TIA 942-A connection requirements

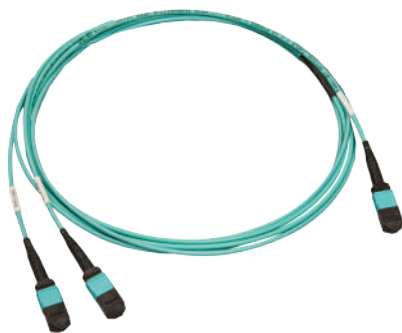

MTP® 400G Y Harness Cables (16F-32F)



MTP®Trunk Cable

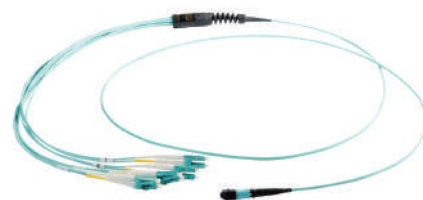

MTP® to LC Fan-Out Cable

STAR Patch Cords

STAR Patch Cords are designed to deliver maximum connectivity performance in a minimal space.

Features:

- Bend insensitive fibers MM OM3, OM4 or SM (G.657/A2)
- Minimal insertion loss and back reflection
- Compliant with GR-326-CORE and TIA-568-C.3, OM3 (IEC 60793-2-10 type A1a.2), OM4 (type A1a.3), SM (ITU-T G.657/A2) and RoHS

Specifications:

Reversible LC Uniboot Patch Cord

- Enabling high performance which exceeds TIA/EIA 604-10 (LC FOCIS 10)
- Using a single, unified jacket for both fibers, with a diameter of only 1.6mm, enabling up to 50% savings in cabling volume, as well as tool-less polarity reversibility

MTP® up to 400G Patch Cord

- Pre-terminated with MTP® Elite connectors, enabling high performance which exceeds TIA/EIA 604-5 (MPO FOCIS)
- Contains 8/16/32 fibers in a 3/3.6 mm thin, flexible LSZH FR jacket
- Available in either direct or crossed polarity

Benefits:

- Allows quick Moves Adds & Changes (MACs) and easy maintenance of structured cabling
- High quality solution for seamless connectivity, providing excellent performance
- Field-proven - Installed successfully at high density, high-availability facilities such as Disaster Recovery Plan (DRP), Business Continuity Planning (BCP) and central Data-Center sites



Reversible LC Uniboot Patch Cord

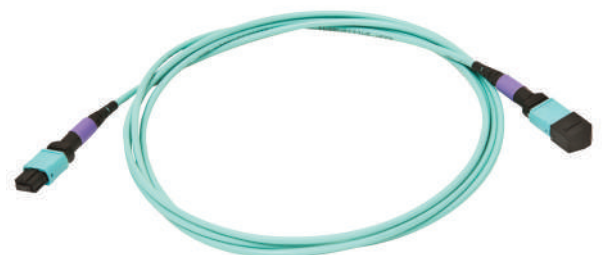

MTP® Patch Cord

Product Verification Tests:

- Apex offset
- Radius of curvature
- Fiber Height
- Roughness
- Tilt

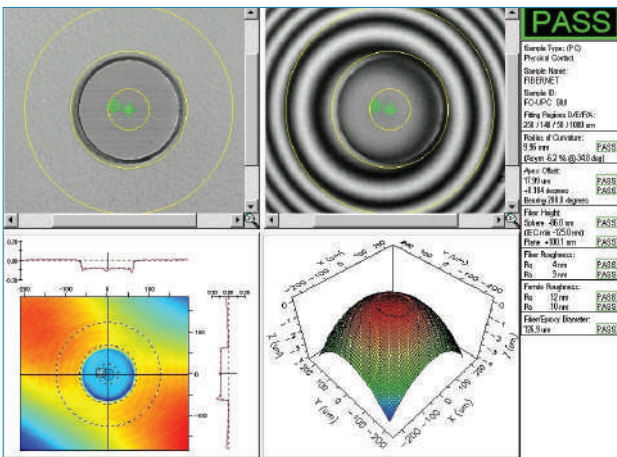

Reversible LC Uniboot Connectors

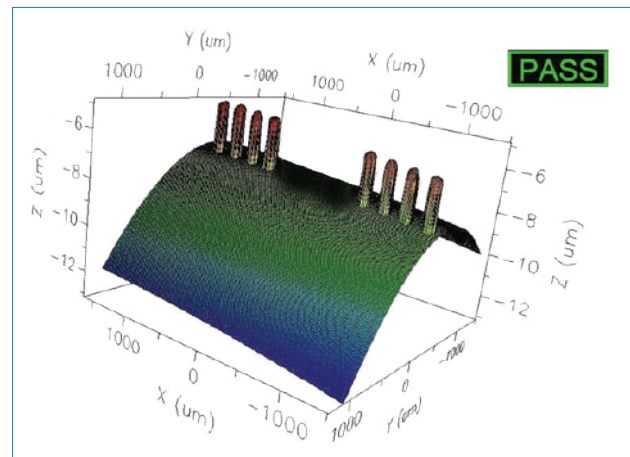

MTP® Connectors

Data Center Cabling Architecture

International International standards require that Data Center cabling architecture supports both current and future bit rates. Operational and cost considerations require that cabling is structured and practical, allowing easy migration from LC based, up to 400 G systems, based on Low Loss MPO connectivity (MTP®).

Parameters for Multi-Mode (850nm Ethernet) channel, as specified in standard IEEE 802.3:

IEEE Standard	Data Rate	Connector Type	OM3	OM4	SMF
IEEE 802.3ae	10 Gb/s	LC	300 M	550 M	10km, 40km
IEEE 802.3by	25 Gb/s	LC / MTP	70 M	100 M	—
IEEE 802.3bm	40 Gb/s	MTP	100 M	150 M	10km
IEEE P802.3bm	100 Gb/s	MTP	100 M	150 M	10 km, 40km
* IEEE P802.3bs	400 Gb/s	MTP	—	100 M	500m, 2Km, 10Km

* 400 Gbit/s Ethernet over optical fiber using multiple 25G lanes

Polarity Management - Method A:

STAR400 Module is assembled according to Method A as described in the ANSI/TIA 568-C.3 standard. The polarity is managed at Patch Cord level, meaning that all the modules and MTP® backbone cables maintain direct polarity. The polarity is switched using a crossed Patch Cord at only one side of the link. The Patch Cords on the other side are direct and so are any others (if exist) along the link.

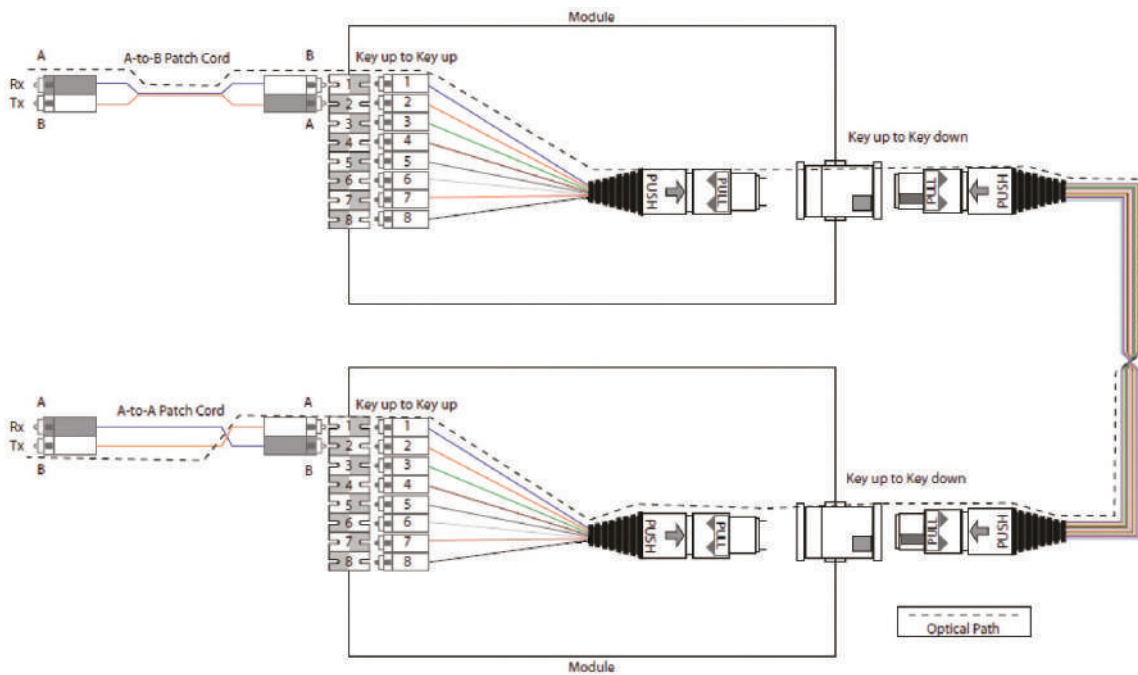

STAR400 Cabling Architecture

10G Implementation

MTP®-LC modules are being used for connecting pre-terminated 8-fiber MTP® backbone cables to high density LC duplex uniboot patch cord.

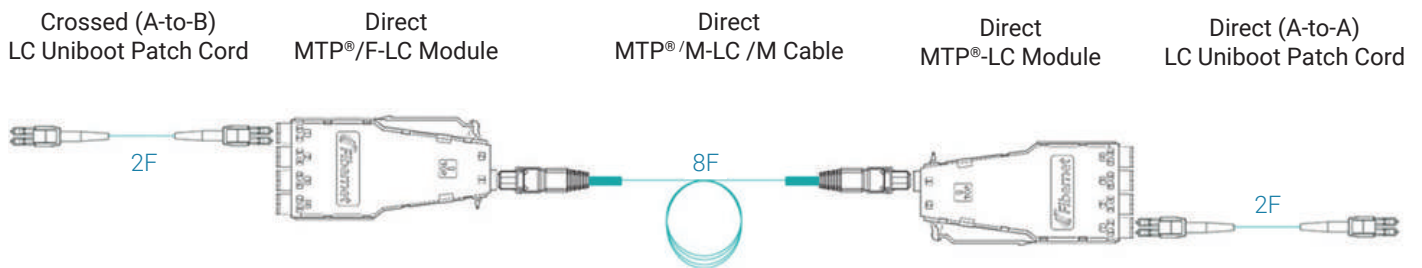

The polarity is managed according to Method A using direct polarity components along the channel – except for one crossed (A-to-B) Patch Cord at one end. Direct polarity cables (both MTP® and LC) are easily identified by a purple mark on each side.

Migration from 10G to 40G/100Gn

The MTP®-LC modules are replaced with MTP®-MTP® modules in order to connect the same pre-terminated 8-fiber MTP® backbone cables to MTP® Patch Cords.

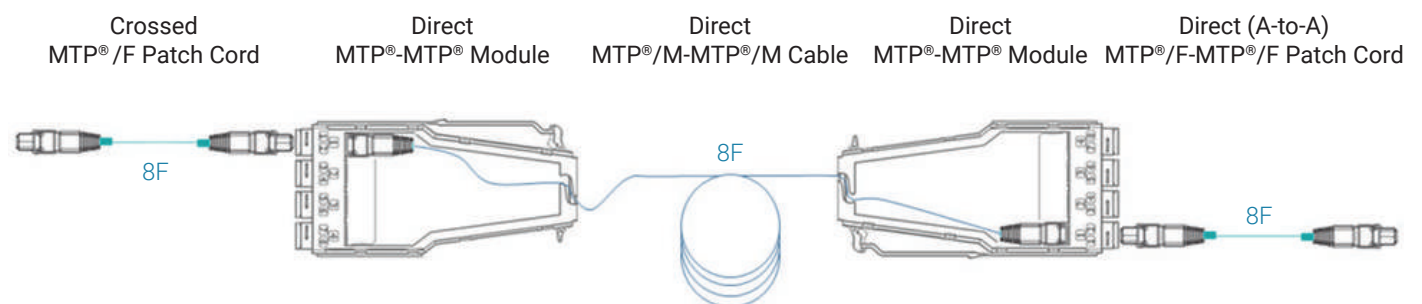

Method A polarity management is maintained by using one crossed MTP® Patch Cord as the only crossed component along the link

Migration to 200G

The MTP® Patch Cords are replaced with MTP® Y Patch Cords, containing one 16 fibers MTP® connector to two 8 fibers MTP® connectors. The same MTP®-MTP® modules and the same pre-terminated 8-fiber MTP® backbone cables are being used. Additional 16 fiber backbone cables and Patch Cord can be added for expansion.

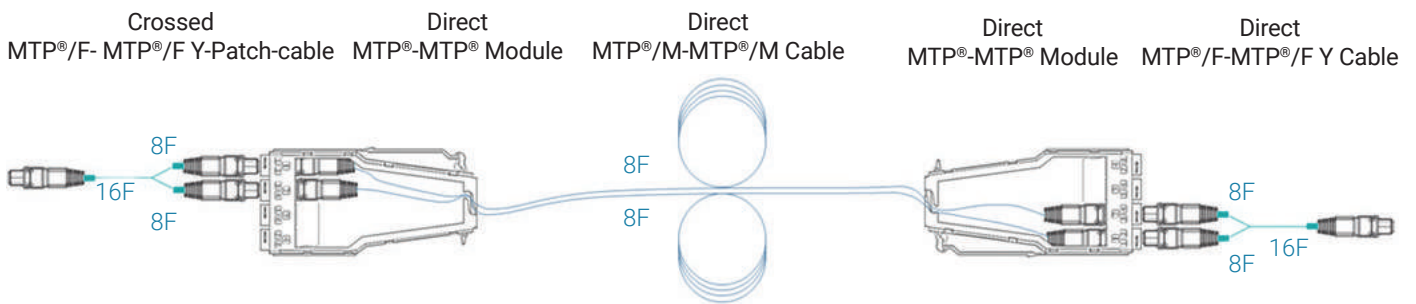

Method A polarity management is maintained by using one crossed MTP® Y Patch Cord as the only crossed component along the link.

Migration to 400G

The MTP® Patch Cords are replaced with two MTP® Y Patch Cords, containing one 32 fibers MTP® connector to four 8 fibers MTP® connectors. The same MTP®-MTP® modules and the same pre-terminated 8-fiber MTP® backbone cables are being used. Additional 32 fiber backbone cables and Patch Cord can be added for expansion.

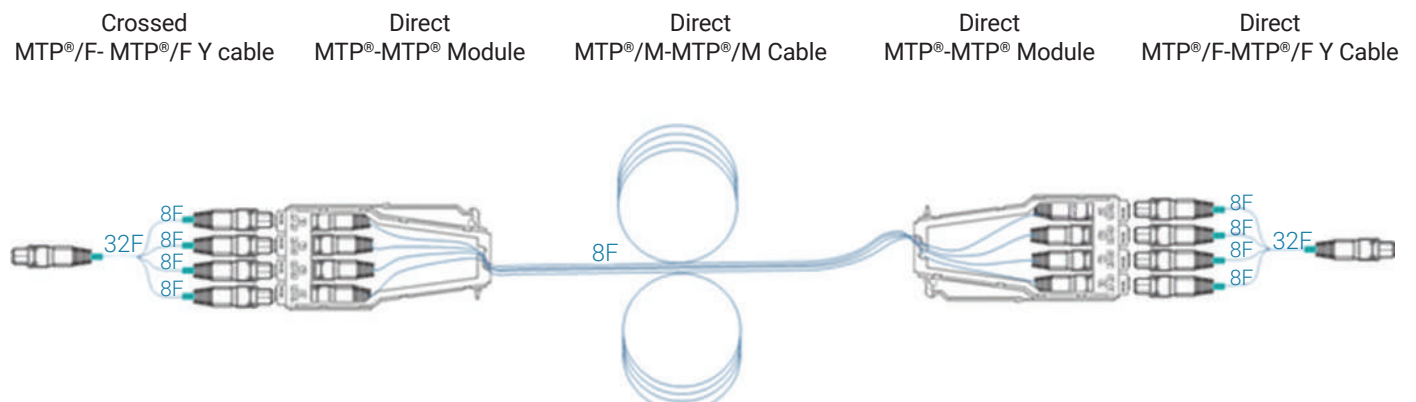

Method A polarity management is maintained by using crossed MTP® Y Patch Cord as the only crossed component along the link.

DEVELOPMENT

Fibernet's team is at the forefront of fiber optics and electronics technologies with a series of in-house products in addition to working with market leaders to design and develop sophisticated devices from conception to mass-production.

PRODUCTS

Fibernet provides high-quality fiber optics and electronic solutions to diverse industries, enabling them to keep pace with technological innovations, offer faster networks, meet customer expectations and increase profitability.

MANUFACTURING

Fibernet leverages its two decades of fiber-optics and electronics expertise as well as state of the art facilities and equipment to manufacture top quality turn-key solutions in compliance with the strictest international standards.



www.fibernet-tech.com

Fibernet Ltd, Hi-Tech Park, Yokneam Illit | 9 Hakidma St, P.O Box 512, Israel 2069206
Tel: +972-4-9095555 | Fax: +972-4-9590047 | E-mail: sales@fibernet.co.il